

**Planta Baixa Cobertura**  
Área: 57,00 m<sup>2</sup>  
Esc.: 1/75

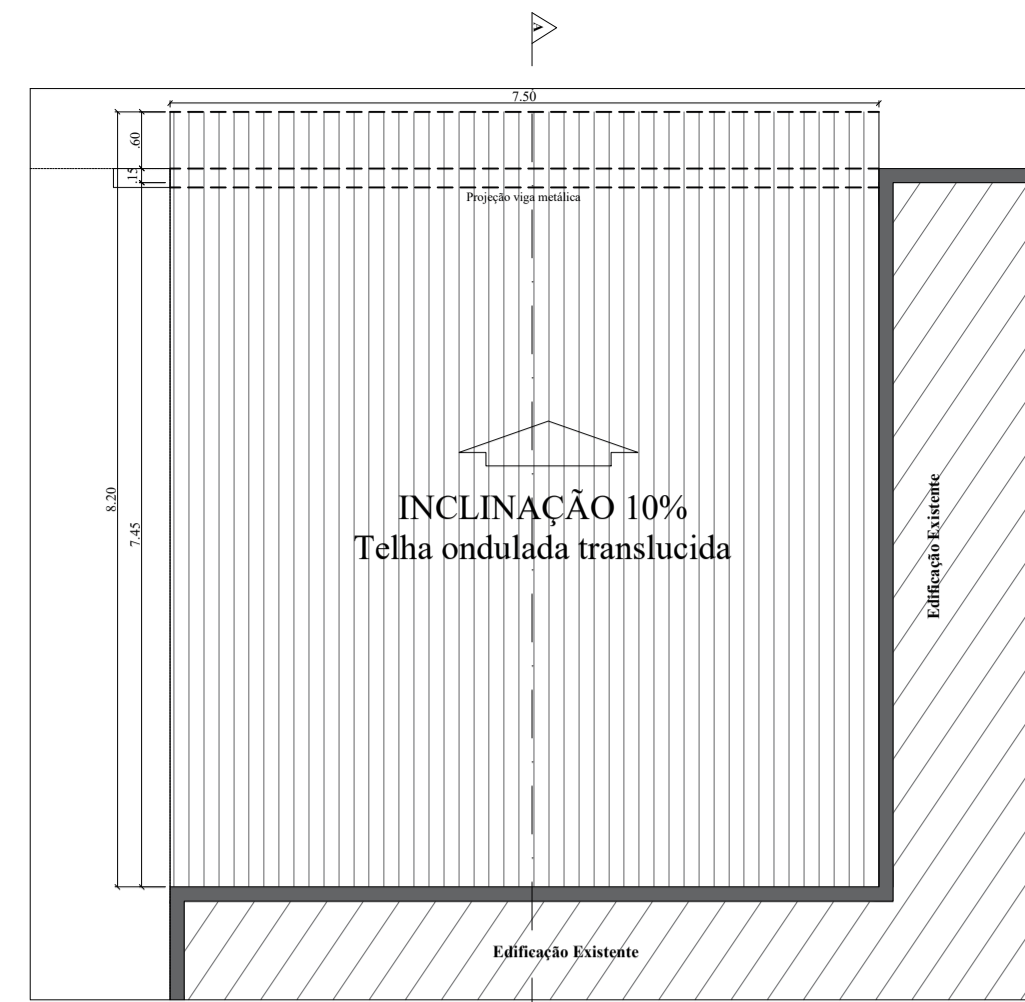

**Planta de Cobertura**  
Área: 57,00 m<sup>2</sup>  
Esc.: 1/75

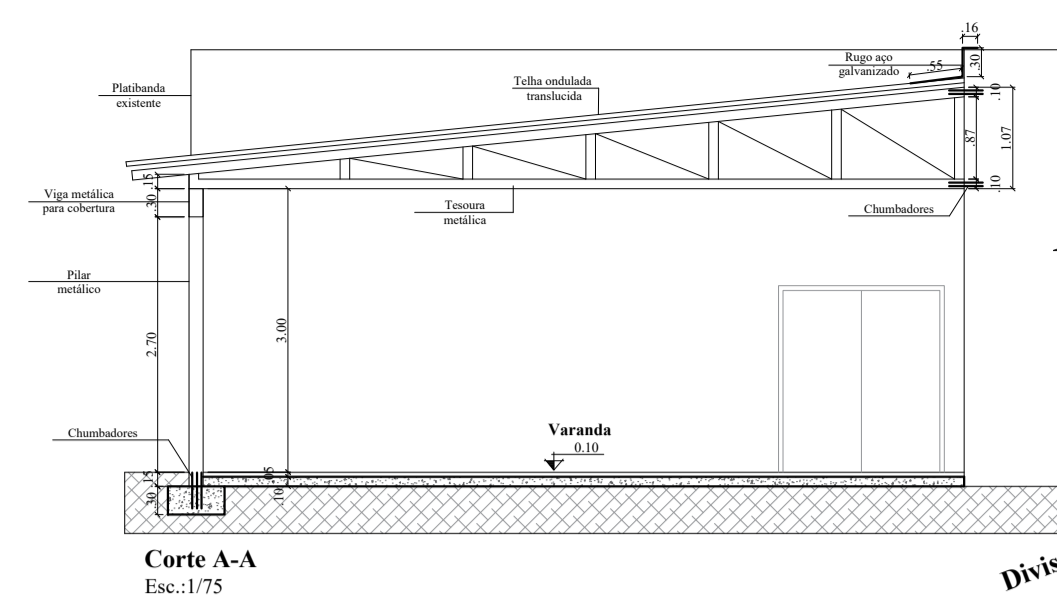

**Corte A-A**  
Esc.: 1/75

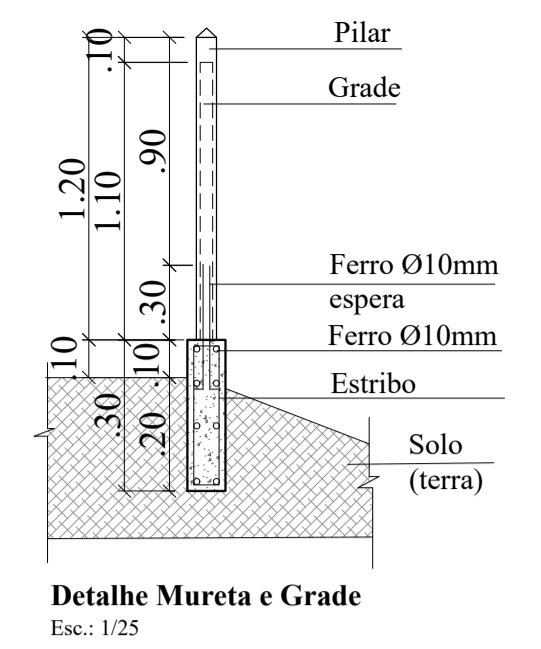

**Detalhe Mureta e Grade**  
Esc.: 1/25

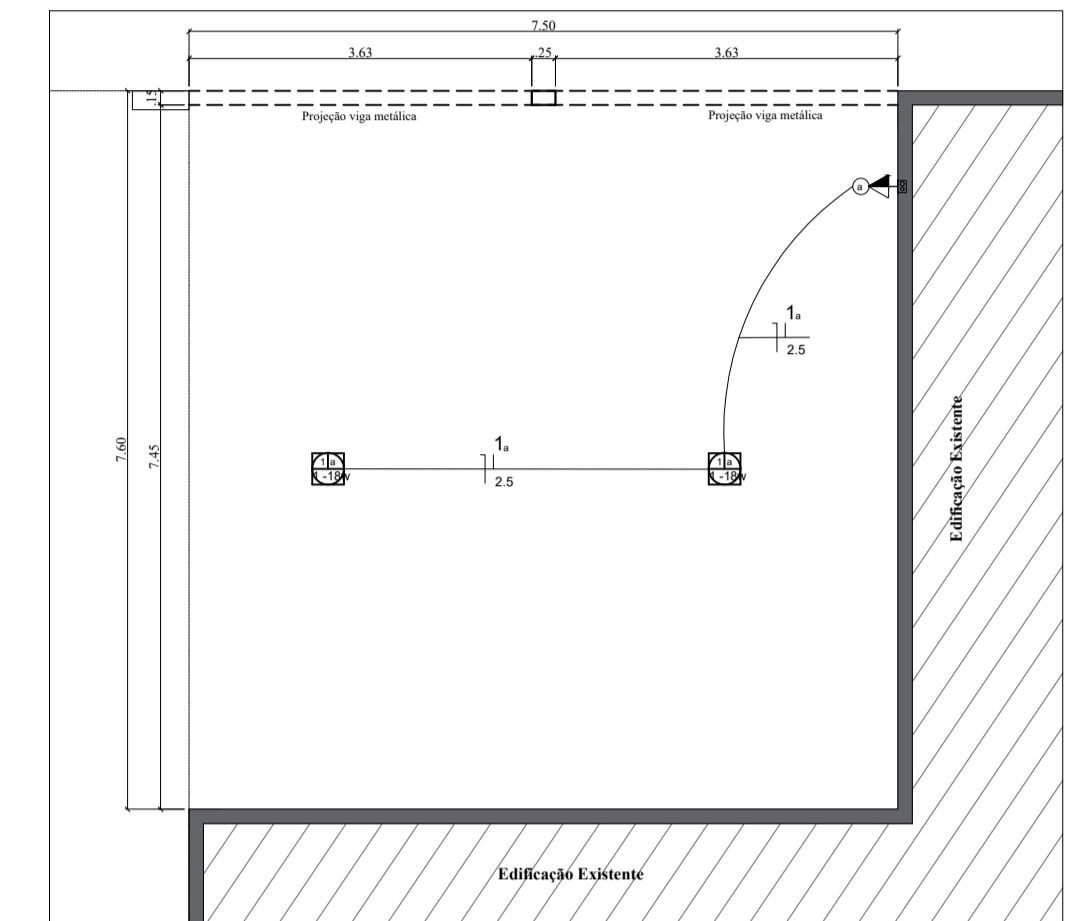

**Planta Baixa Cobertura Elétrica**  
Esc.: 1/75

- Legenda:
- Interruptor
  - Luminaria
  - Tomada média h: 1,20m
  - Tomada alta h: 2,20m

QUADRO DE CARGAS EXISTENTE						
CIRCUITO	LÂMPADAS	100 W	300 W	TOMADAS	TOTAL WATT	CARGA EQUIV. AMP
1	2	36 W		1	36	2,5
2						
TOTAL					36 W	1x1,0

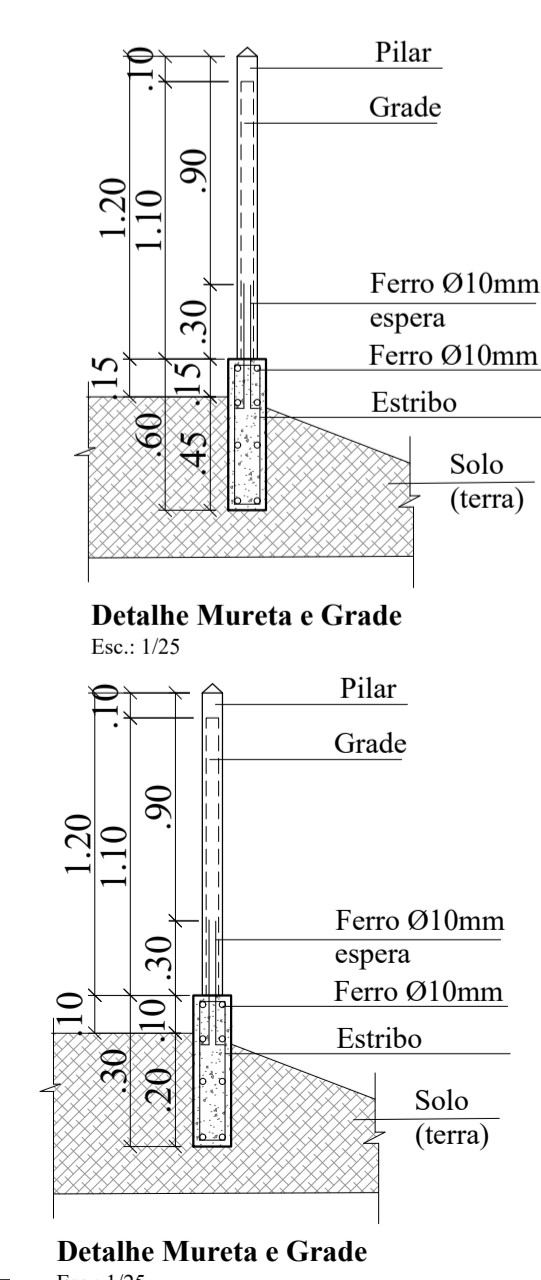
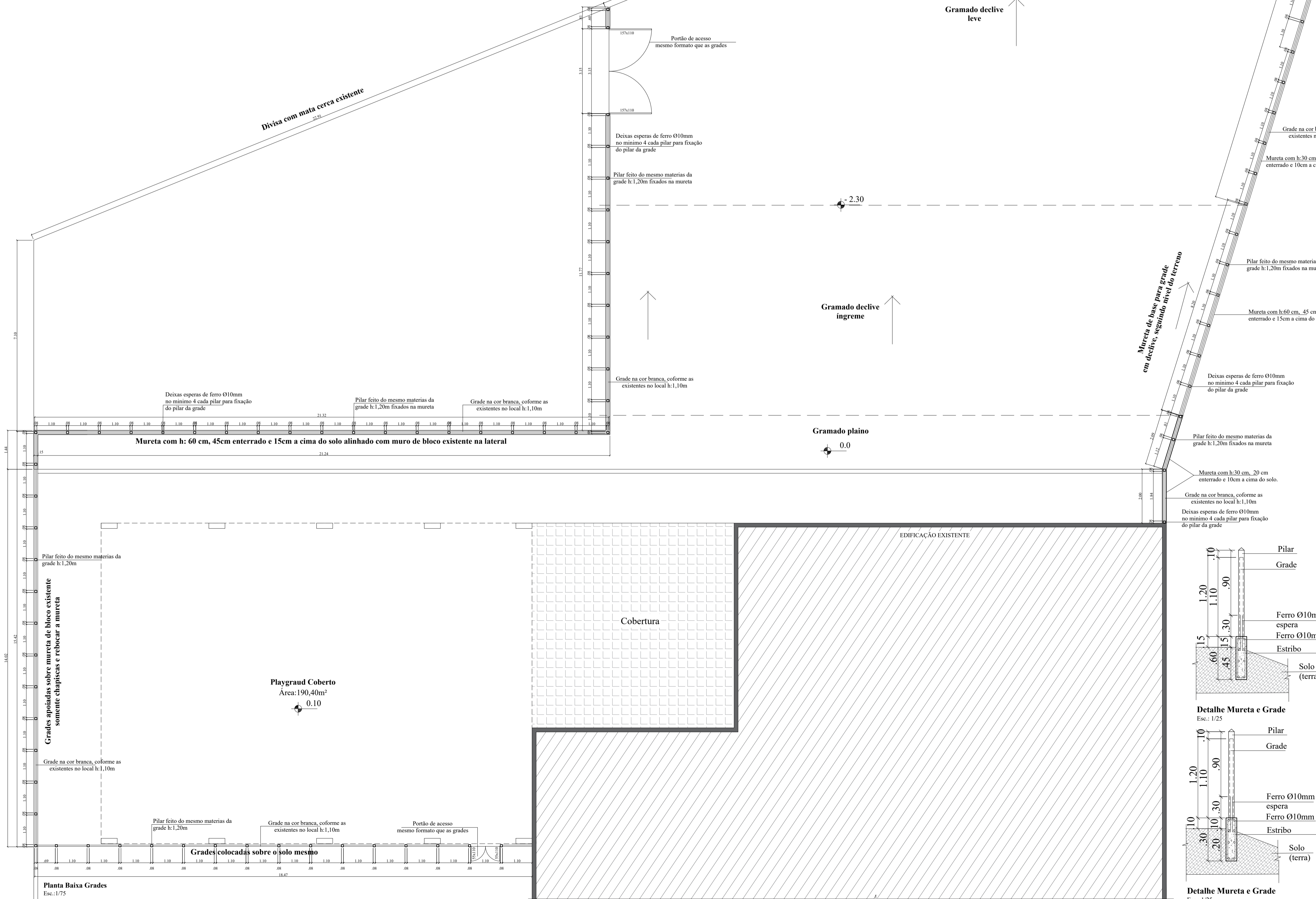

**Detalhe Mureta e Grade**  
Esc.: 1/25

**Detalhe Mureta e Grade**  
Esc.: 1/25

**IF** **Indianara Follmann**  
Arquiteta e Urbanista | CAU/SC 149411-2  
(49) 991040658  
arquitetaindianara@gmail.com

**Projeto Prefeitura Municipal de Tunápolis - SC**

DESCRIÇÃO  
Planta baixa grades  
Planta baixa cobertura  
Planta cobertura  
Planta baixa cobertura elétrica

PRANCHA  
**01/02**

ARQUIVO  
00000

RESPONSÁVEL TÉCNICO:  
INDIANARA FOLLMANN  
ARQUITETA E URBANISTA CAU/SC A104830-9

PROPRIETÁRIOS:  
PREFEITURA MUNICIPAL DE TUNÁPOLIS  
CNPJ: 784.861.98-0001/52

ESCALA  
INDICADA

DATA  
14/12/2022

ÁREA